

# HGVR 44 BOX SYSTEM

## METHOD

- MEASURE & CUT HG1 TO LENGTH INCLUNG TOP/BOTTOM OVERHANG
- MEASURE & CUT BOX IN BETWEEN TIMBERS (SQUARE/ANGLED)
- SLIDE BOTTOM CLEATS ONTO HG1
- INSERT HG1 INTO BOX
- SLIDE TOP CLEATS ONTO HG1 & FIX IN POSITION
- POSITION ASSEMBLY IN PLACE & FIX TOP CLEATS TO TIMBER
- CENTALISE BOX & FIX TO HG1
- PLACE CHANNEL WEATHER BAR IN POSITION OVER CLEATS (TOP&BOTTOM)
- REPEAT ASSEMBLY
- GLAZE IN UNIT & END CLOSURE (NOTCH IF REQUIRED)
- FIX PRESSURE PLATE & SNAP ON CAP



TOP FIXED CLEAT

BOTTOM SLIDING CLEAT

POSITIVE FIX BOX

# Typical Cross Sectional Detail

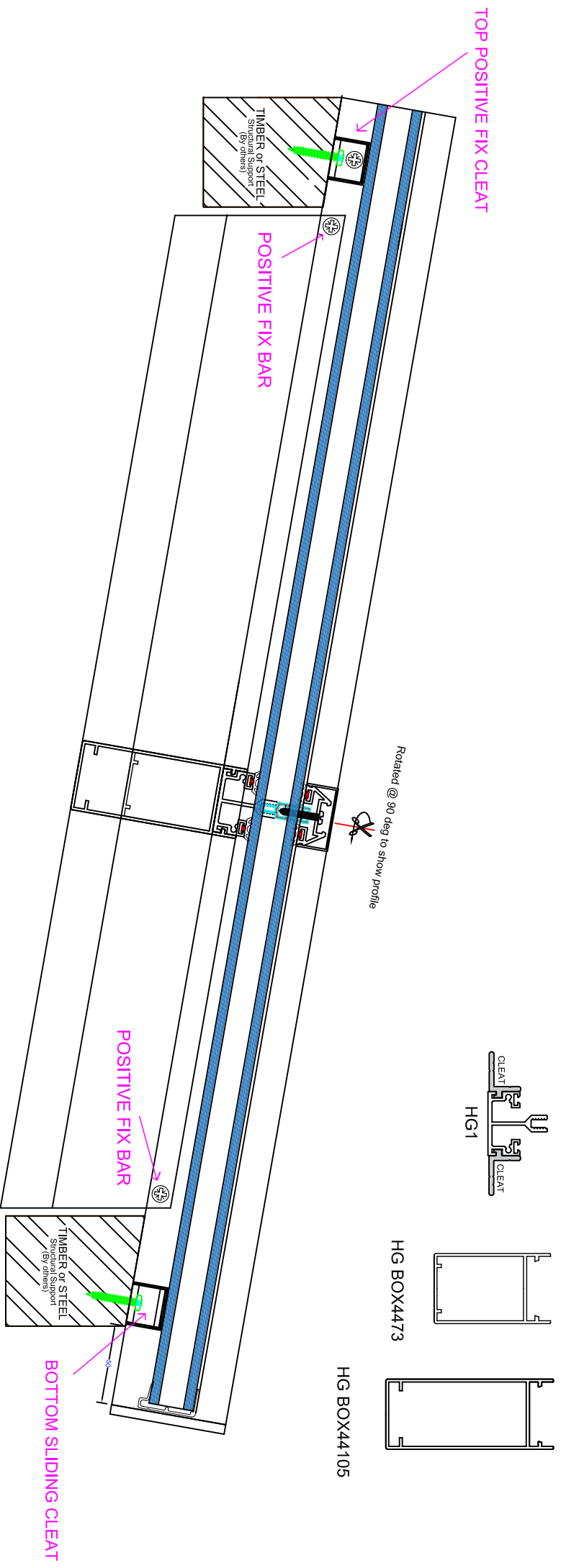

GLAZING SYSTEM

HGVR 44 BOX SYSTEM

DATE

MARCH 2018

PAGE No.

DRAWING REF

CROSS SECTION DETAIL - SLOPE

NOT TO SCALE

DRAWN

GH

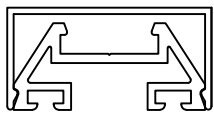
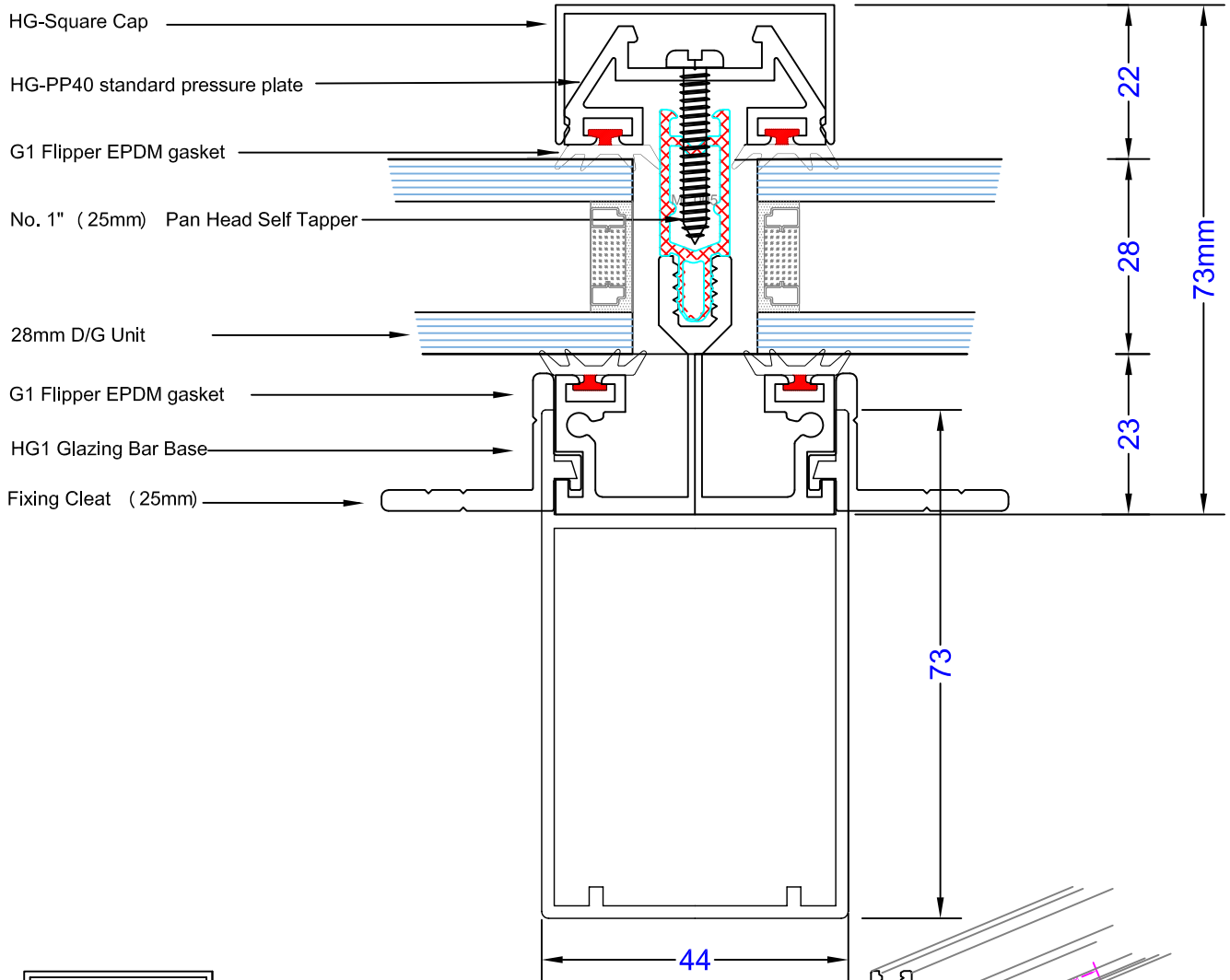
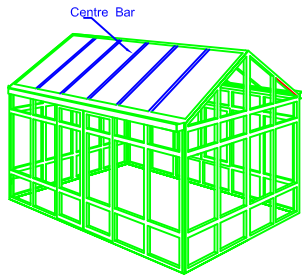

Square cap  
(Standard)

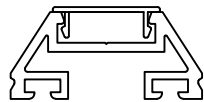

Sloping cap

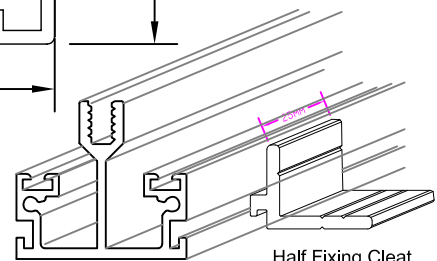

Half Fixing Cleat

NOT TO SCALE



Howells

t. 01384 820060  
f. 01384 820061  
e. sales@howellsglazing.co.uk

GLAZING SYSTEM  
HG44\_73/ DG 28

DATE  
MAR 2018

PAGE No. 05b

DRAWING REF  
CENTRE BAR ASSEMBLY

SCALE 1:1 @ A4

DRAWN  
GH

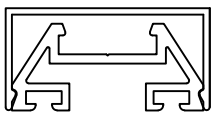
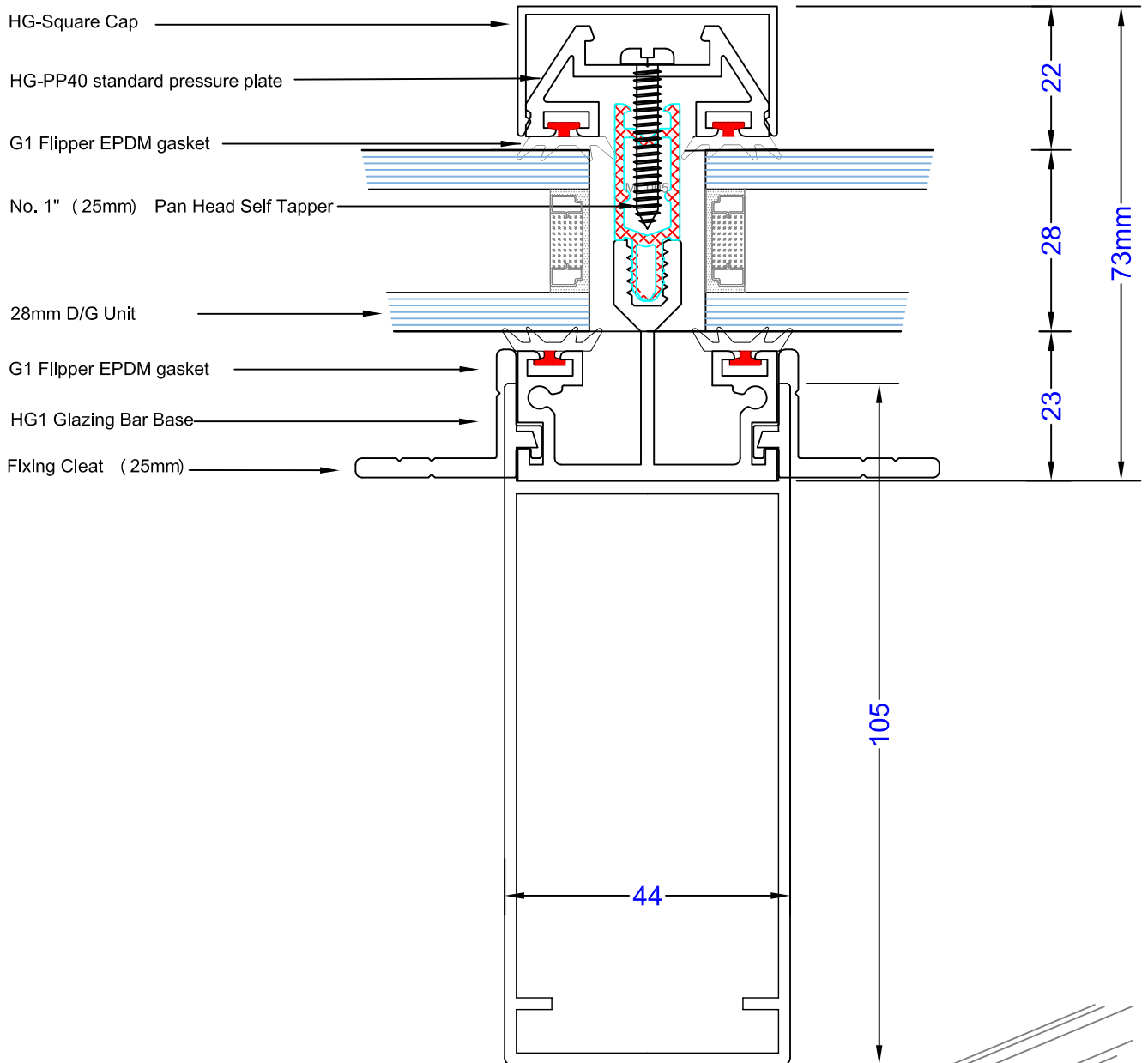
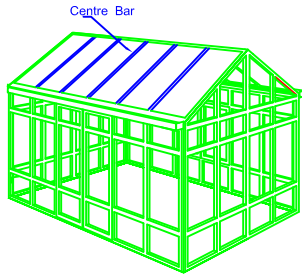

Square cap  
(Standard)

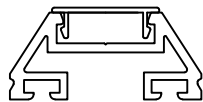

Sloping cap

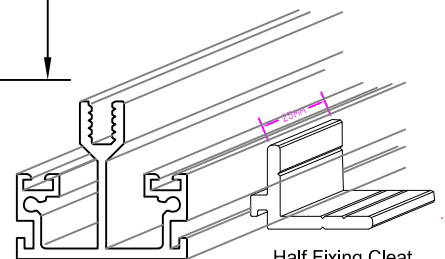

Half Fixing Cleat

NOT TO SCALE



Howells

t. 01384 820060  
 f. 01384 820061  
 e. sales@howellsglazing.co.uk

GLAZING SYSTEM  
 HG44\_105/ DG 28

DATE  
 MAR 2018

PAGE No. 05c

DRAWING REF  
 CENTRE BAR ASSEMBLY

SCALE 1:1 @ A4

DRAWN  
 GH

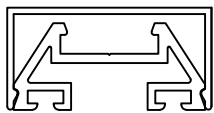
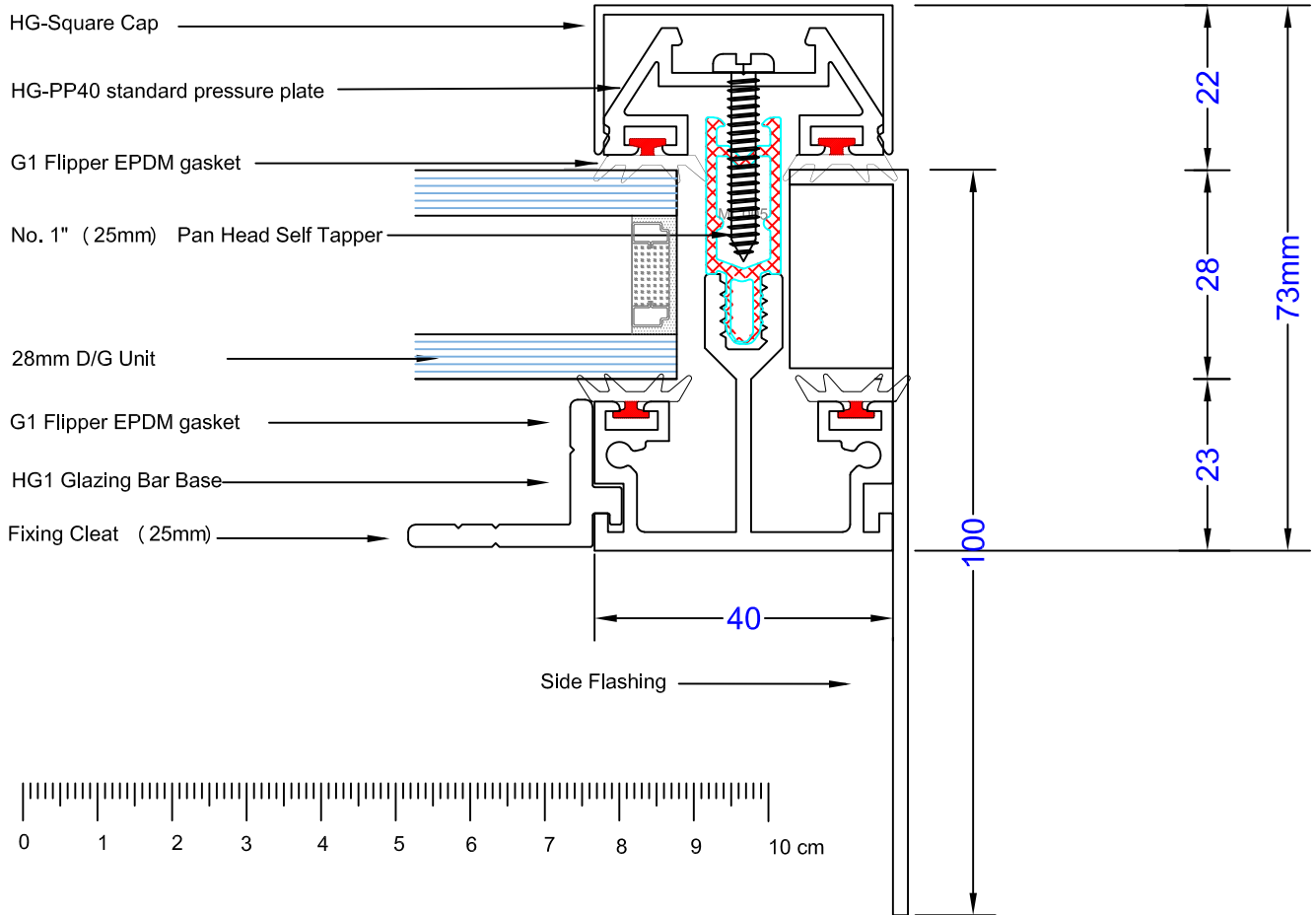
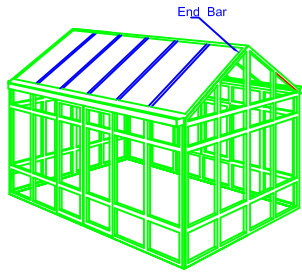

Square cap  
(Standard)

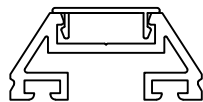

Sloping cap

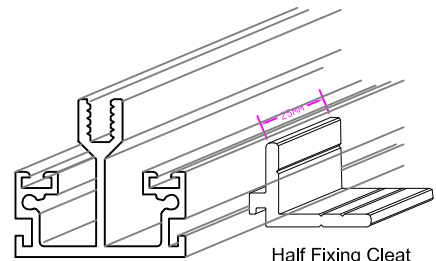

Half Fixing Cleat

NOT TO SCALE



t. 01384 820060  
 f. 01384 820061  
 e. sales@howellsglazing.co.uk

GLAZING SYSTEM  
**HG1/ DG 28**

DATE  
**MAR 2018**

**PAGE No. 05a**

DRAWING REF  
**END BAR ASSEMBLY**

SCALE 1:1 @ A4

DRAWN  
**GH**

# WALL END BAR

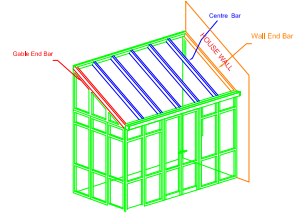

Lead Flashing

WALL BAR PROFILE

HOUSE WALL

20,6  
28

Double Sided Tape

28m End Bar Filler

40

73

105

25mm

Double Sided Tape

25mm

Wall bar angle plate

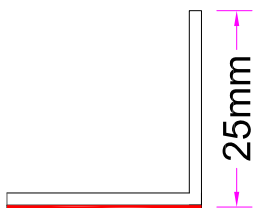

# Typical Cross Sectional Detail

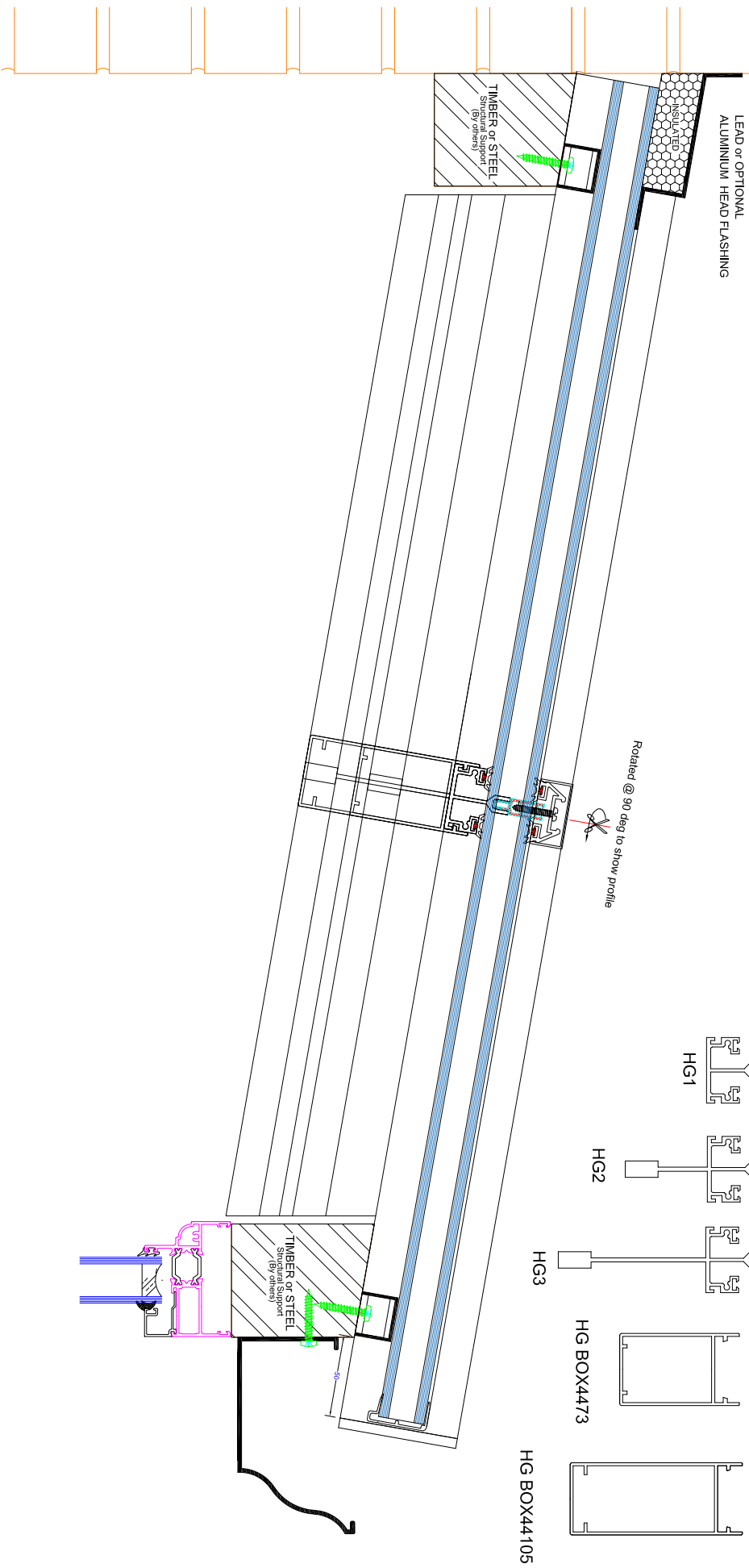

GLAZING SYSTEM  
**HG1 / 2 / 3 / BOX**

DATE  
**MARCH 2018**

**PAGE No.**

DRAWING REF  
**CROSS SECTION DETAIL - SLOPE**

**NOT TO SCALE**

DRAWN  
**GH**



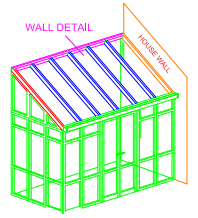

# WALL DETAIL

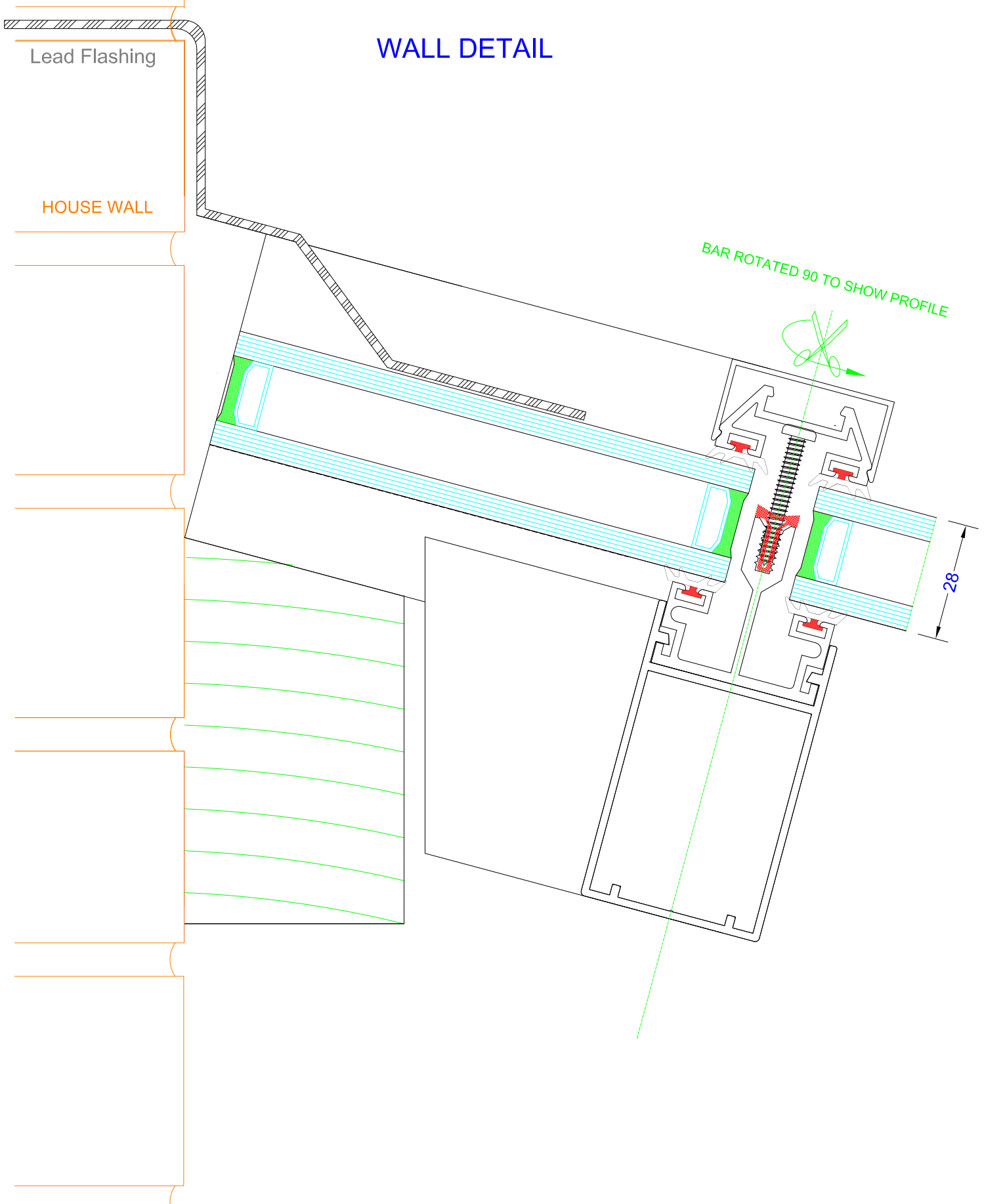

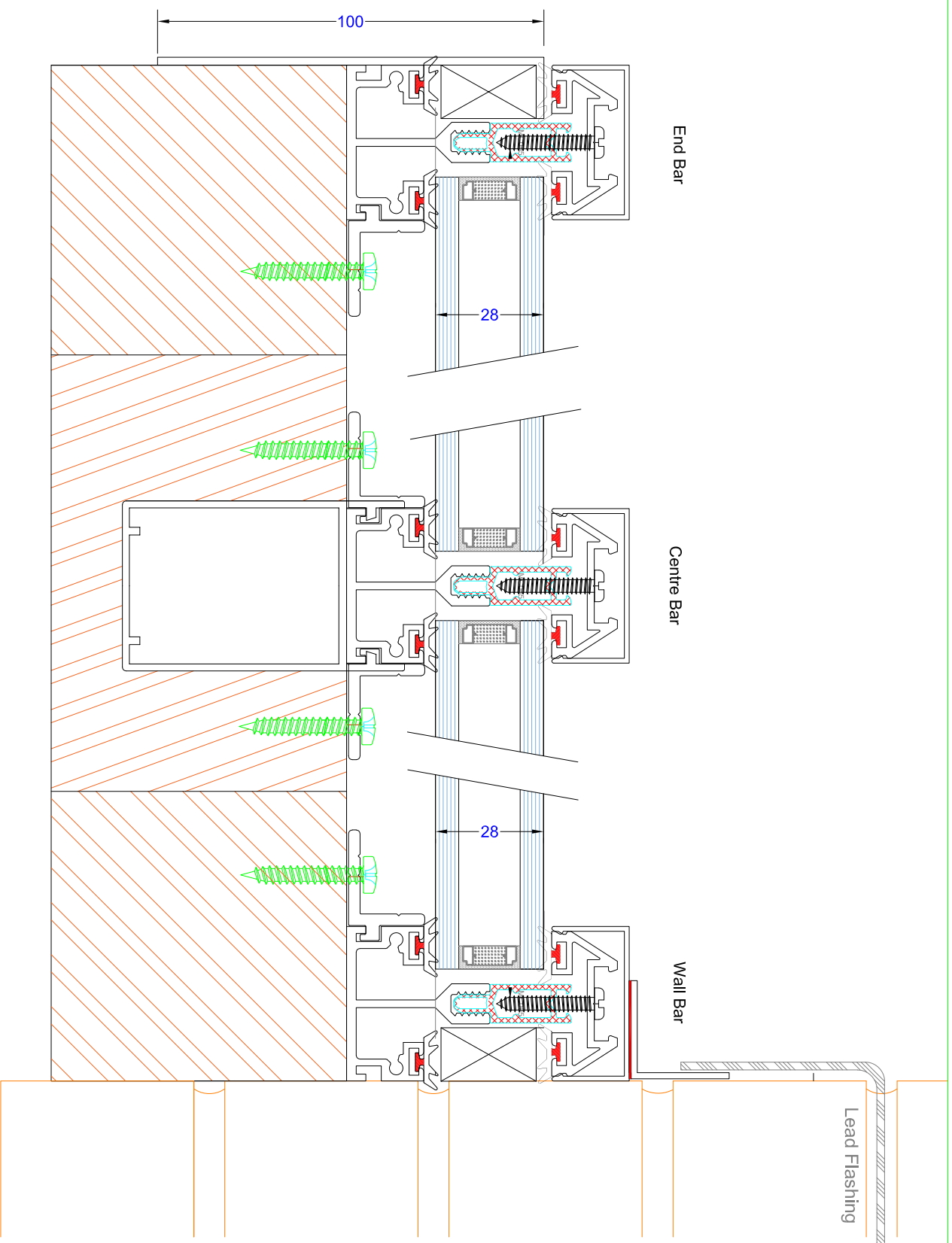

GLAZING SYSTEM

End / Centre Bar Detail

DRAWING REF

CROSS SECTION DETAIL

DATE

MARCH 2018

PAGE No.

SCALE 1:1 @ A4

DRAWN

GH

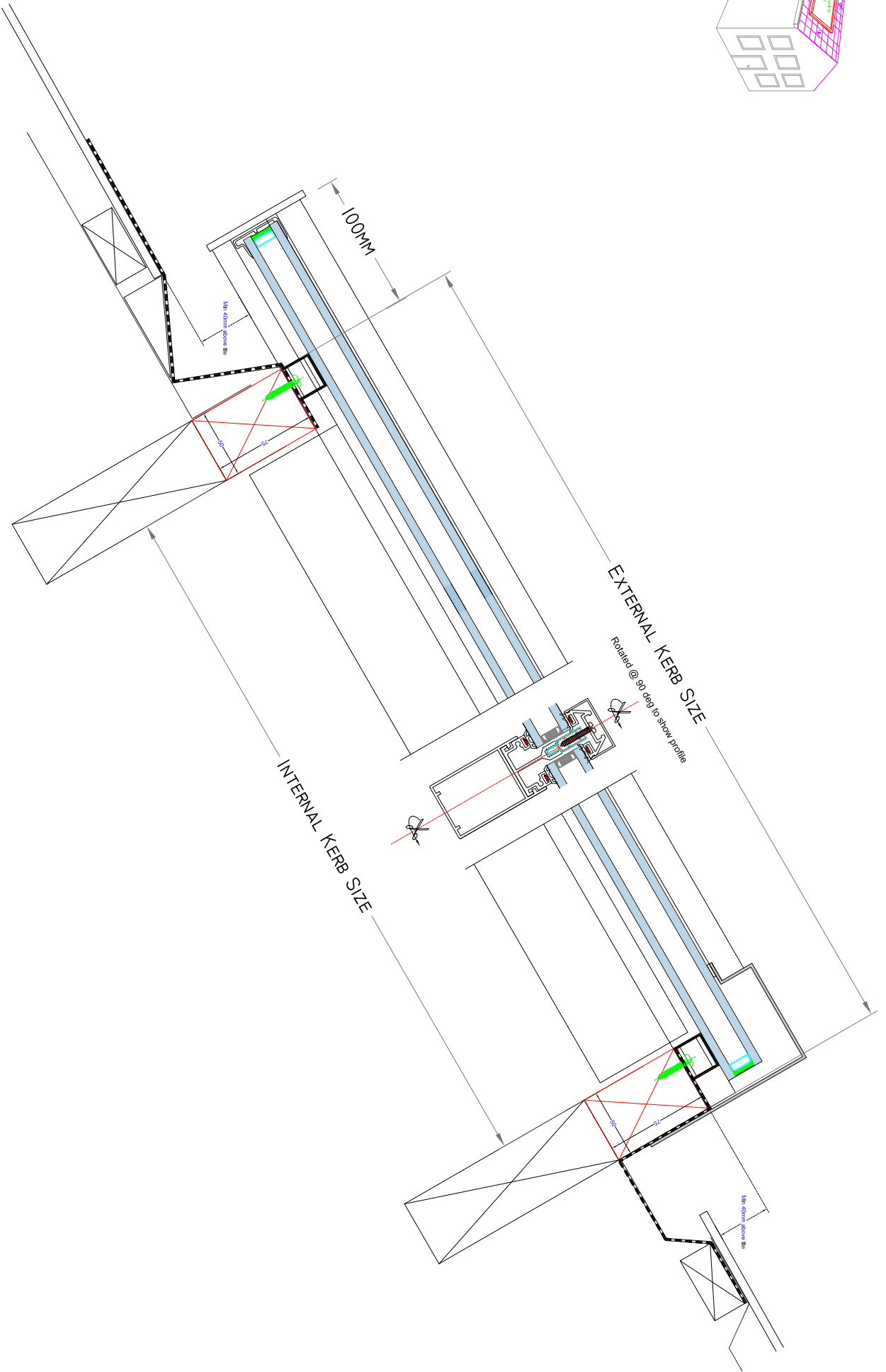
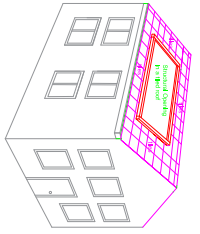

Howells

t. 01384 820060  
f. 01384 820060  
e. sales@howellsglazing.co.uk

GLAZING SYSTEM

HGVR BOX - In tiled roof

DRAWING REF

CROSS SECTION VIEW - SLOPE

DATE

14.03.2018

PAGE

HGVR BOX\_201

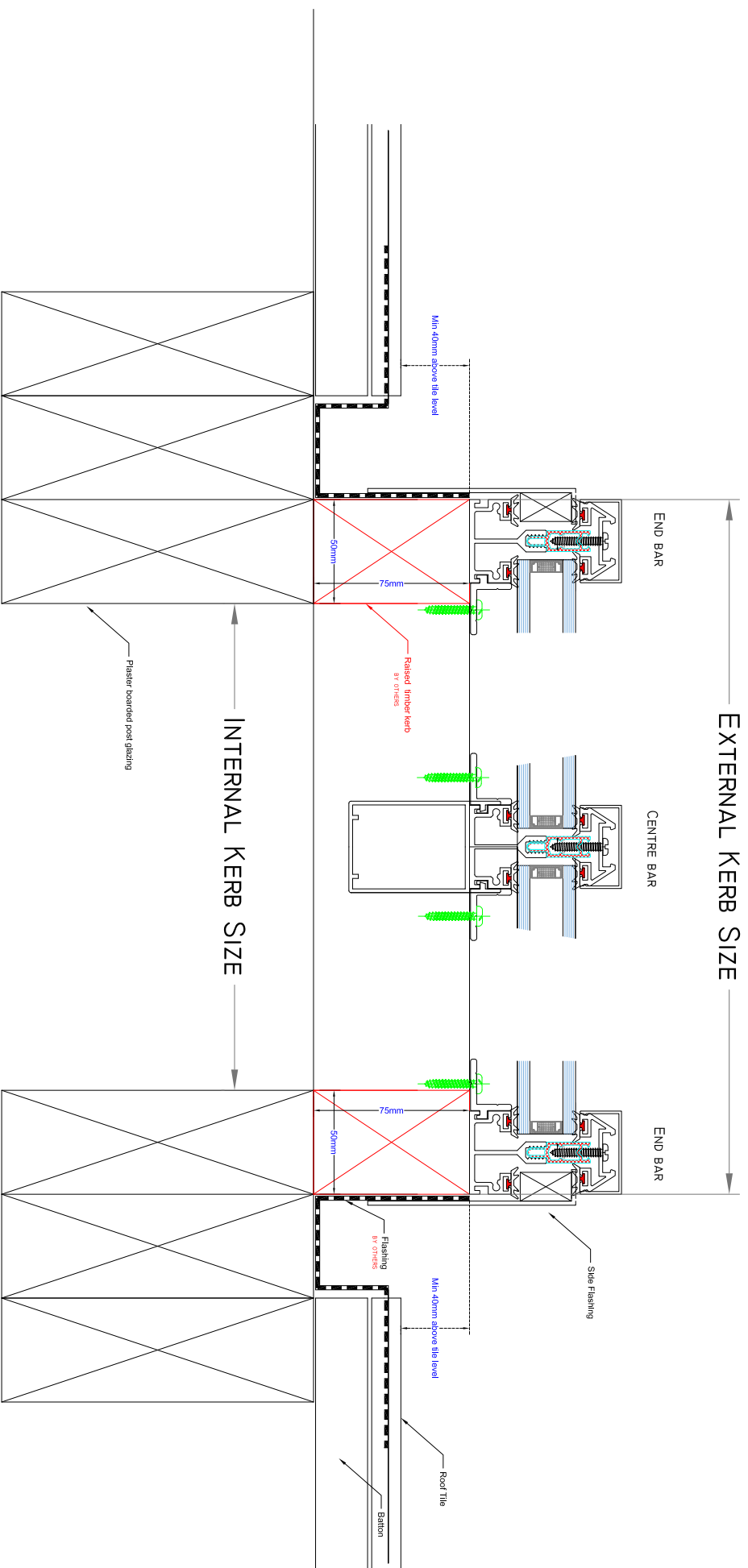

GLAZING SYSTEM

HGVR BOX - In tiled roof

DRAWING REF

CROSS SECTION VIEW - END & CENTRE BARS

DATE

14.03.2018

PAGE

HGVR BOX\_202



Howells

t. 01384 820060

f. 01384 820060

e. sales@howellsglazing.co.uk

Typical Roof Vent

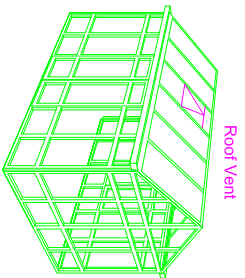

HG Thermally Broken Roof Vent  
Vent Assembly (Electric)

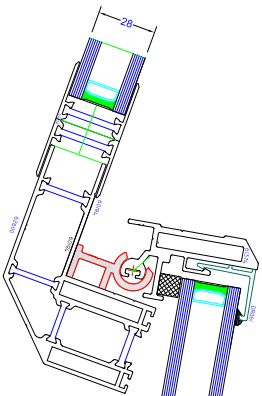

Aluminium Thermally Broken Polyamide Vent

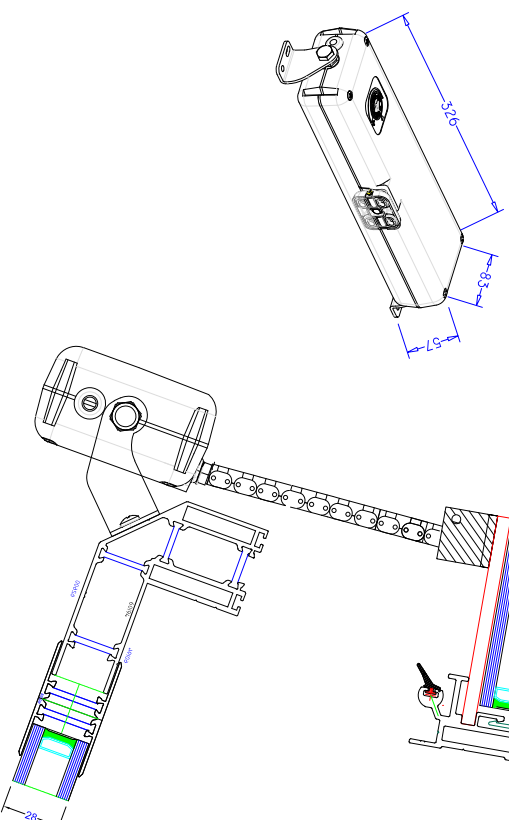

Howells

t. 01384 820060  
f. 01384 820060  
e. sales@howellsglazing.co.uk

GLAZING SYSTEM

HG57 Medium Duty

DRAWING REF

HG57 ROOF VENT

DATE

14.03.2018

PAGE

HG57\_008